



OMEPHA ALEMANIA MÉXICO S.A. de C.V.
Fuente de la Lluvia 263
Colonia Balcones de Valle
78280 San Luis Potosí, S.L.P., México

Tel (444) 820 5465
Cel (444) 104 1350
info@omepha-alemania-mexico.com
www.omepha-alemania-mexico.com



HSS Flachsenker, Kegelsenker

E HSS counterbores, countersinks

I HSS allargatori per sedi viti, svasatori



D Übersicht
HSS-Senker

E Overview
HSS countersinks

I Sommario
Svasatori HSS

D Die Schnittwerte für alle Werkzeuge entnehmen Sie bitte unserem separaten Zerspanungshandbuch.

E You will find the cutting conditions for all tools in our separate cutting manual.

I Per i parametri di lavorazione per tutti gli utensili richiedete il nostro manuale tecnico.

Kegelsenker / Countersinks
Svasatori



Norm / Standard	DIN 334	DIN 335		DIN 335	
Typ / Typ / Tipo	60°	90°	90°	90°	90°
Form / Forma	C	C	C	C	C
Schneidstoff / Cutting material / Acciaio punta	HSS-Co5	HSS-Co5	HSS-Co5	HSS-Co5	HSS-Co5
Beschichtung / Coating / Rivestimento			ALUNIT®		ALUNIT®
Ø mm	6,3-25	6,3-31	6,3-31	4,3-31	5-31
Code / Codice	2280	2390	2397	2290	2297
Seite / Page / Pagina	342	342	342	343	343

Geeignet für / Suitable for / Adatte per

Stähle < 400 N/mm² Steels < 400 N/mm² Acciai < 400 N/mm²					
Stähle < 850 N/mm² Steels < 850 N/mm² Acciai < 850 N/mm²					
Stähle < 1.100 N/mm² Steels < 1.100 N/mm² Acciai < 1.100 N/mm²					
Stähle < 1.300 N/mm² Steels < 1.300 N/mm² Acciai < 1.300 N/mm²					
Stähle > 45 HRC Steels > 45 HRC Acciai > 45 HRC					
Rostfreie Stähle < 850 N/mm² Stainless steels < 850 N/mm² Acciai inossidabili < 850 N/mm²					
Rostfreie Stähle > 850 N/mm² Stainless steels > 850 N/mm² Acciai inossidabili > 850 N/mm²					
Grauguss, Temperguss Cast iron, malleable cast iron Ghisa grigia, ghisa malleabile					
Titan- und Titanlegierung Titanium and titanium alloys Titanio e leghe di Titanio					
Kupfer, Messing Copper, brass Rame, ottone					
Aluminium Aluminium Alluminio					
Kunststoffe Plastics Materie plastiche					

D **Übersicht**
HSS-Senker

E **Overview**
HSS countersinks

I **Sommario**
Svasatori HSS

Kegelsenker / Countersinks Svasatori	Flachsenker / Counterbores Allargatori per sedi viti			Führungszapfen / Pilots Guide	
					
DIN 335	DIN 373			DIN 1868	
90°	N	N	N		
D	fein / fine	mittel / medium / media		fein / fine	mittel / medium / media
HSS-Co5	HSS	HSS	HSS	HSS	HSS
25-50	M3 - M12	M4 - M12	M10 - M24	M10 - M24	M10 - M24
2330	2140	2150	2160	2180	2190
344	345	346	346	347	348
					
					
					
					
					
					
					
					
					
					
					
					
					



D **Kegelsenker**
DIN 334 C, 60°

Einsatzbereich:

Für alle E- und NE-Metalle, Kunststoffe hart und weich. Universell einsetzbares Entgrat- und Senkwerkzeug für Bohrungen aller Art. Sehr gute Schneideigenschaften, durch radialen Hinterschliff leicht nachschärfbar an der Spanfläche.



E **Countersinks**
DIN 334 C, 60°

Range of application:

For ferrous and non-ferrous metals, synthetic materials soft and hard. Universal deburring and sink tool for all kind of borings. Excellent cutting features guarantee a smooth surface; profile relief facilitates an easy regrind.



I **Svasatori**
DIN 334 C, 60°

Impiego:

Adatti per tutti i materiali ferrosi, non ferrosi, plastiche dure e dolci, per sbavature e svasature di tutti i tipi di fori. Ottime proprietà di taglio, mentre la spoglia radiale permette una facile riaffilatura.



d1 mm	d2 mm	d3 h9 mm	l1 mm	Z	Code 2280 Art.-Nr.
6,30	1,60	5,00	45	3	0 2280006301 00
8,00	2,00	6,00	50	3	0 2280008001 00
12,50	3,20	8,00	56	3	0 2280012501 00
16,00	4,00	10,00	63	3	0 2280016001 00
20,00	5,00	10,00	67	3	0 2280020001 00
25,00	6,30	10,00	71	3	0 2280025001 00

D **Kegelsenker ungleiche Schneiden**
DIN 335 C, 90°

Einsatzbereich:

Für alle E- und NE-Metalle, Kunststoffe hart und weich. Universell einsetzbares Entgrat- und Senkwerkzeug für Bohrungen aller Art. Sehr gute Schneideigenschaften, durch ungleichgeteilte Schneiden.

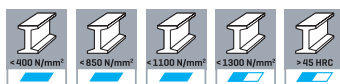

E **Countersinks different cutting**
DIN 335 C, 90°

Range of application:

For ferrous and non-ferrous metals, synthetic materials soft and hard. Universal deburring and sink tool for all kind of borings. Excellent cutting features guarantee a smooth surface by unequally divided cutting edges.

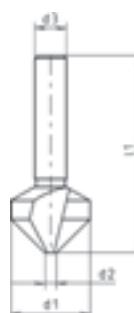

I **Svasatori disuguale tagliente**
DIN 335 C, 90°

Impiego:

Adatti per tutti i materiali ferrosi, non ferrosi, plastiche dure e dolci, per sbavature e svasature di tutti i tipi di fori. Perfette proprietà di taglio, a causa di disuguale tagliente.



ALLUNIT®

d1 mm	d2 mm	d3 h9 mm	l1 mm	Z	Code 2390 Art.-Nr.	Code 2397 Art.-Nr.
6,30	1,50	5,00	45	3	0 2390006301 00	0 2397006301 00
10,40	2,50	6,00	50	3	0 2390010401 00	0 2397010401 00
12,40	2,80	8,00	56	3	0 2390012401 00	0 2397012401 00
16,50	3,20	10,00	60	3	0 2390016501 00	0 2397016501 00
20,50	3,50	10,00	63	3	0 2390020501 00	0 2397020501 00
25,00	3,80	10,00	67	3	0 2390025001 00	0 2397025001 00
31,00	4,20	12,00	71	3	0 2390031001 00	0 2397031001 00

D Kegelsenker
DIN 335 C, 90°

Einsatzbereich:

Für alle E- und NE-Metalle, Kunststoffe hart und weich. Universell einsetzbares Entgrat- und Senkwerkzeug für Bohrungen aller Art. Gute Schneideigenschaften, durch radialen Hinterschliff leicht nachschärfbar an der Spanfläche.

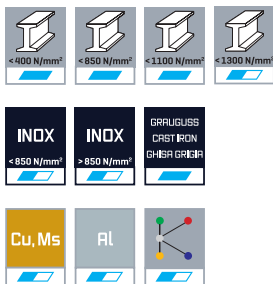

E Countersinks
DIN 335 C, 90°

Range of application:

For ferrous and non-ferrous metals, synthetic materials soft and hard. Universal deburring and sink tool for all kind of borings. Good cutting features guarantee a smooth surface; profile relief facilitates an easy regrind.

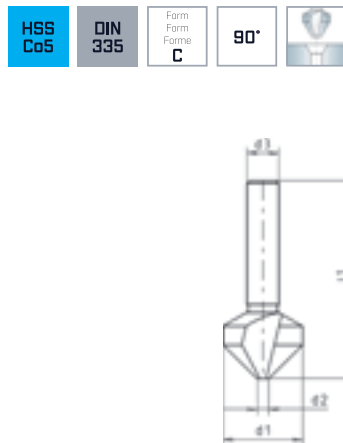

I Svasatori
DIN 335 C, 90°

Impiego:

Adatti per tutti i materiali ferrosi, non ferrosi, plastiche dure e dolci, per sbavature e svasature di tutti i tipi di fori. Ottime proprietà di taglio, mentre la spoglia radiale permette una facile riaffilatura.

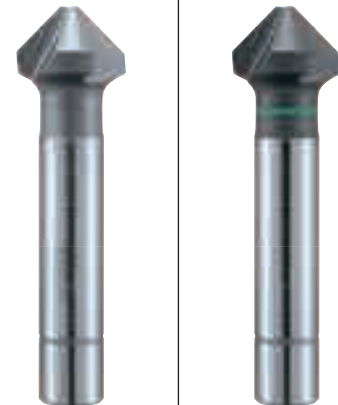

ALLUNIT®

d1 mm	d2 mm	d3 h9 mm	l1 mm	Z	Code 2290 Art.-Nr.	Code 2297 Art.-Nr.
4,30	1,30	4,00	40	3	0 2290004301 00	
5,00	1,50	4,00	40	3	0 2290005001 00	0 2297005001 00
5,30	1,50	4,00	40	3	0 2290005301 00	
6,00	1,50	5,00	45	3	0 2290006001 00	0 2297006001 00
6,30	1,50	5,00	45	3	0 2290006301 00	0 2297006301 00
8,00	2,00	6,00	50	3	0 2290008001 00	0 2297008001 00
8,30	2,00	6,00	50	3	0 2290008301 00	0 2297008301 00
9,40	2,20	6,00	50	3	0 2290009401 00	
10,00	2,50	6,00	50	3	0 2290010001 00	0 2297010001 00
10,40	2,50	6,00	50	3	0 2290010401 00	0 2297010401 00
11,50	2,80	8,00	56	3	0 2290011501 00	
12,40	2,80	8,00	56	3	0 2290012401 00	0 2297012401 00
13,40	2,90	8,00	56	3	0 2290013401 00	
15,00	3,20	10,00	60	3	0 2290015001 00	0 2297015001 00
16,50	3,20	10,00	60	3	0 2290016501 00	0 2297016501 00
19,00	3,50	10,00	63	3	0 2290019001 00	0 2297019001 00
20,50	3,50	10,00	63	3	0 2290020501 00	0 2297020501 00
23,00	3,80	10,00	67	3	0 2290023001 00	
25,00	3,80	10,00	67	3	0 2290025001 00	0 2297025001 00
31,00	4,20	12,00	71	3	0 2290031001 00	0 2297031001 00



HSS Senker
HSS countersinks
HSS svasatori

D Kegelsenker mit MK-Schaft **E** Countersinks with MT-Shank
DIN 335 D, 90°

Einsatzbereich:

Für alle E- und NE-Metalle, Kunststoffe hart und weich. Universell einsetzbares Entgrat- und Senkwerkzeug für Bohrungen aller Art. Sehr gute Schneideigenschaften, durch radialen Hinterschliff leicht nachschärfbar an der Spanfläche.



Range of application:

For ferrous and non-ferrous metals, synthetic materials soft and hard. Universal deburring and sink tool for all kind of borings. Excellent cutting features guarantee a smooth surface; profile relief facilitates an easy regrind.



I Svasatori cono morse
DIN 335 D, 90°

Impiego:

Adatti per tutti i materiali ferrosi, non ferrosi, plastiche dure e dolci, per sbavature e svasature di tutti i tipi di fori. Ottime proprietà di taglio, mentre la spoglia radiale permette una facile riaffilatura.



d1 mm	d2 mm	l1 mm	Z	Code 2330 Art.-Nr.
25,00	3,80	106	2 3	0 2330025001 00
31,00	4,20	112	2 3	0 2330031001 00
34,00	4,50	118	2 3	0 2330034001 00
37,00	4,80	118	2 3	0 2330037001 00
40,00	10,00	140	3 3	0 2330040001 00
50,00	14,00	150	3 3	0 2330050001 00

D Flachsenker
DIN 373, fein

Einsatzbereich:

Für alle E- und NE-Metalle, Kunststoffe hart und weich. Zur Verwendung in Durchgangslöcher nach DIN 273 Gütegrad „fein“ bei Einzel- und Serienfertigung. Zum Versenken von Innen-sechskantschrauben DIN 912, 6912, 7984 und Zylinderschrauben ISO 1207 (DIN 84).

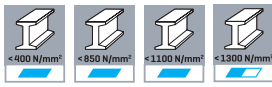

E Counterbores
DIN 373, fine

Range of application:

For ferrous and non-ferrous metals, synthetic materials soft and hard, for working in through holes according to DIN 273 Quality level "fine". Suitable in individual and mass production. For countersinking Allen screws DIN 912, 6912, 7984 and cheese-head screws ISO 1207 (DIN 84).

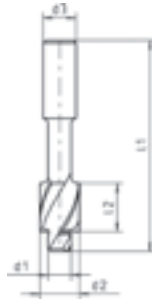

I Allargatori per sedi viti
DIN 373, fine

Impiego:

Adatti per tutti i materiali ferrosi, non ferrosi, plastiche dure e dolci, per fori passanti secondo DIN 273 Grado di precisione "fino", sia per lavorazioni singole che di serie. Per accicare le viti ad esagono cavo DIN 912, 6912, 7984 e le viti a testa cilindrica ISO 1207 (DIN 84).



	d1 _{e8} mm	d2 _{z9} mm	d3 _{h9} mm	l1 mm	l2 mm	Z	Code 2140 Art.-Nr.
M 3	3,20	6,00	5,00	71	14	3	0 2140006001 00
M 4	4,30	8,00	5,00	71	14	3	0 2140008001 00
M 5	5,30	10,00	8,00	80	18	3	0 2140010001 00
M 6	6,40	11,00	8,00	80	18	3	0 2140011001 00
M 8	8,40	15,00	12,50	100	22	3	0 2140015001 00
M10	10,50	18,00	12,50	100	22	3	0 2140018001 00
M12	13,00	20,00	12,50	100	22	3	0 2140020001 00



D Flachsenker
DIN 373, mittel

Einsatzbereich:
Für alle E- und NE-Metalle, Kunststoffe hart und weich. Zur Verwendung in Durchgangslöcher nach DIN 273 Gütegrad „mittel“ bei Einzel- und Serienfertigung. Zum Versenken von Innensechskantschrauben DIN 912, 6912, 7984 und Zylinderschrauben ISO 1207 [DIN 84].

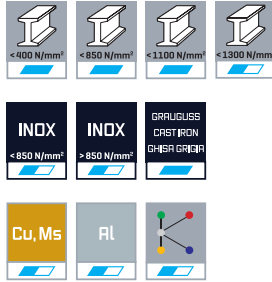

E Counterbores
DIN 373, medium

Range of application:
For ferrous and non-ferrous metals, synthetic materials soft and hard, for working in through holes according to DIN 273 Quality level "medium". Suitable in individual and mass production. For countersinking Allen screws DIN 912, 6912, 7984 and cheese-head screws ISO 1207 [DIN 84].

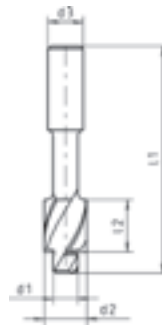

I Allargatori per sedi viti
DIN 373, media

Impiego:
Adatti per tutti i materiali ferrosi, non ferrosi, plastiche dure e dolci, per fori passanti secondo DIN 273 Grado di precisione "medio", sia per lavorazioni singole che di serie. Per accicare le viti ad esagono cavo DIN 912, 6912, 7984 e le viti a testa cilindrica ISO 1207 [DIN 84].



	d1 e8 mm	d2 z9 mm	d3 h9 mm	l1 mm	l2 mm	Z	Code 2150 Art.-Nr.
M 4	4,50	8,00	5,00	71	14	3	0 2150008001 00
M 5	5,50	10,00	8,00	80	18	3	0 2150010001 00
M 6	6,60	11,00	8,00	80	18	3	0 2150011001 00
M 8	9,00	15,00	12,50	100	22	3	0 2150015001 00
M10	11,00	18,00	12,50	100	22	3	0 2150018001 00
M12	13,50	20,00	12,50	100	22	3	0 2150020001 00

D Flachsenker für
auswechselbare
Führungszapfen,
MK-Schaft, DIN 375

Einsatzbereich:
Für alle E- und NE-Metalle, Kunststoffe hart und weich. Zur Verwendung in Durchgangslöcher nach DIN 273 bei Einzel- und Serienfertigung.



E Counterbores for
detachable pilots,
MT-shank, DIN 375

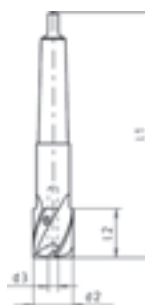

Range of application:
For ferrous and non-ferrous metals, synthetic materials soft and hard, for working in through holes according to DIN 273. Suitable in individual and mass production.



I Allargatori con guida
intercambiabile,
Cono morse, DIN 375

Impiego:
Adatti per tutti i materiali ferrosi, non ferrosi plastiche dure e dolci, per fori passanti secondo DIN 273, sia per lavorazioni singole che di serie.



	d2 _{z9} mm	d3 mm	l1 mm	l2 mm		Z	Code 2160 Art.-Nr.
M10	18,00	5,00	140	25	2	3	0 2160018001 00
M12	20,00	5,00	140	25	2	3	0 2160020001 00
M14	24,00	6,00	150	30	2	3	0 2160024001 00
M16	26,00	8,00	180	35	3	3	0 2160026001 00
M18	30,00	8,00	180	35	3	3	0 2160030001 00
M20	33,00	10,00	190	40	3	3	0 2160033001 00
M24	40,00	10,00	190	40	3	3	0 2160040001 00

D Führungzapfen**DIN 1868****Einsatzbereich:**

Für Flachsener DIN 375 und Kegelsenker
DIN 1867 für Durchgangslöcher nach DIN 69.

E Pilots**DIN 1868****Range of application:**

For counterbores DIN 375 and countersinks
DIN 1867 for body holes according to DIN 69.

I Guide**DIN 1868****Impiego:**

Per allargatori DIN 375 e svasatori DIN 1867. Adatte
per fori passanti secondo DIN 69.

HSS **DIN
1868**

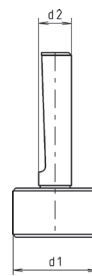

für Durchgangslöcher „fein“ / for body holes „fine“ / per fori passanti „fine“

	d1 _{e8} mm	d2 _{f7} mm	Code 2180 Art.-Nr.
M10	10,50	5,00	0 2180010501 00
M12	13,00	5,00	0 2180013001 00
M14	15,00	6,00	0 2180015001 00
M16	17,00	8,00	0 2180017001 00
M18	19,00	8,00	0 2180019001 00
M20	21,00	10,00	0 2180021001 00
M24	25,00	10,00	0 2180025001 00



D Führungszapfen
DIN 1868

Einsatzbereich:
Für Flachsenker DIN 375 und Kegelsenker
DIN 1867 für Durchgangslöcher nach DIN 69.

E Pilots
DIN 1868

Range of application:
For counterbores DIN 375 and countersinks
DIN 1867 for body holes according to DIN 69.

I Guide
DIN 1868

Impiego:
Per allargatori DIN 375 e svasatori DIN 1867. Adatte
per fori passanti secondo DIN 69.

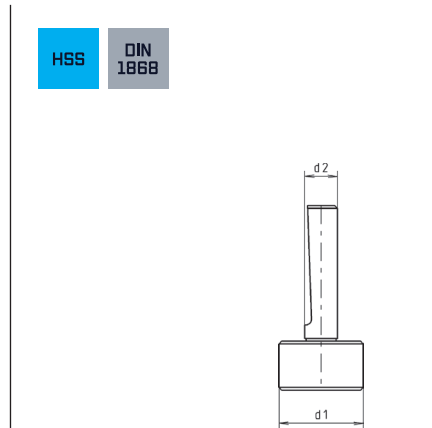

für Durchgangslöcher „mittel“ / for body holes „medium“ / per fori passanti „media“

	d1 _{e8} mm	d2 _{f7} mm	Code 2190 Art.-Nr.
M10	11,00	5,00	0 2190011001 00
M12	13,50	5,00	0 2190013501 00
M14	15,50	6,00	0 2190015501 00
M16	17,50	8,00	0 2190017501 00
M18	20,00	8,00	0 2190020001 00
M20	22,00	10,00	0 2190022001 00
M24	26,00	10,00	0 2190026001 00

D **HSS-Co5**
Kegelsenkersätze
DIN 335 C, 90°

Einsatzbereich:

Für alle E- und NE-Metalle, Kunststoffe hart und weich. Universell einsetzbares Entgrat- und Senkwerkzeug für Bohrungen aller Art. Sehr gute Schneideigenschaften, durch radialen Hinterschliff leicht nachschärfbar an der Spanfläche

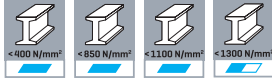

HSS Co5-Kegelsenker-Satz, 4-tlg.
HSS Co5 Countersink set, 4 pcs.
Assortimenti svasatori HSS Co5, 4 pz.

Inhalt / Contents / Contenuto:

Code 2290 Ø 10,4 | 16,5 | 20,5 | 25,0

Art.-Nr. 0 2290000041 00

E **HSS-Co5**
Countersink-sets
DIN 335 C, 90°

Range of application:

For ferrous and non-ferrous metals, synthetic materials soft and hard. Universal deburring and sink tool for all kind of borings. Excellent cutting features guarantee a smooth surface; profile relief facilitates an easy regrind.



HSS Co5-Kegelsenker-Satz, 4-tlg., Alunit®
HSS Co5 Countersink set, 4 pcs., Alunit®
Assortimenti svasatori HSS Co5, 4 pz., Alunit®

Inhalt / Contents / Contenuto:

Code 2297 Ø 10,4 | 16,5 | 20,5 | 25,0

Art.-Nr. 0 2297000041 00

I **Assortimenti svasatori**
HSS-Co5
DIN 335 C, 90°

Impiego:

Adatti per tutti i materiali ferrosi, non ferrosi, plastiche dure e dolci, per sbavature e svasature di tutti i tipi di fori. Ottime proprietà di taglio, mentre la spoglia radiale permette una facile riaffilatura.



HSS Co5-Kegelsenker-Satz, 6-tlg.
HSS Co5-Countersink set, 6 pcs.
Assortimento svasatori HSS Co5, 6 pz.

Inhalt / Contents / Contenuto:

Code 2290 Ø 6,3 | 8,3 | 10,4 | 12,4 | 16,5 | 20,5

Art.-Nr. 0 2290000961 00

