

**OMEPHA ALEMANIA MÉXICO**  
Fuente de la Lluvia 263  
Colonia Balcones de Valle  
78280 San Luis Potosí, S.L.P., México

Tel (444) 820 5465  
Cel (444) 104 1350  
[info@omepha-alemania-mexico.com](mailto:info@omepha-alemania-mexico.com)  
[www.omepha-alemania-mexico.com](http://www.omepha-alemania-mexico.com)

# *Electric Torque Wrench*





VISIBILITY  
KANSAS



# The Electric Torque Wrench LDE/LEW series, 90-13,000 N·m

## LDE series

Großer Eingangsspannungs- und Frequenzbereich (200 – 260V, 47 – 63Hz), international einsetzbar

Electronic R/L switching function

Digital display with visual-acoustic operator guidance for even simpler operation

Optional: Drehmoment-Drehwinkel-Modus

Planet gear unit with Ceramic-Teflon®-coated tooth flanks

Optional LE.TRACK: Data read-out function via non-contact, inductive high-performance interface.

Drop-forged reaction arm made of chrome-vanadium steel for even greater stability

## LEW series

Supplied with individual LÖSOMAT factory calibration certificate







### Rugged gear unit combined with intelligent electronics

Setting new standards with the robust gear unit housing and intelligent electronics under the display: Service functions such as overload and recalibration are displayed to the user. In default, the display shows the torque level. In addition, if required, the display can be changed from torque level to torque value.

### Further functions

Optionally, the electric torque wrench, which is available in straight and angled versions, can be upgraded

with a data read-out function, the torque-rotation angle mode and the fast mode.

### Reliable documentation of results – LE. Track

In response to many requests, the classical electric high-level torque wrench is now also available with the LE-Track documentation function.

Designed for the toughest construction site applications, the inductive data transmission system is used for non-contact transfer of your data to the laptop/PC where you can then conveniently edit it further (see page 7).



## The display and its functions

Torque Mode

5 digit display

Gear display

Select button

Potentiometer wheel for torque settings and menu navigation



Inductive interface

Torque-Angle of Rotation Mode

Fast Modus

Unit display

Enter key

Rotation direction LED to indicate drive direction



Hand grip



From version size LDE-70, the electric torque wrench is supplied with a rotating hand grip to facilitate the easy operation of the device.



The hand grip is included as of size LEW-60 for the angled electric torque wrenches.

Accessories

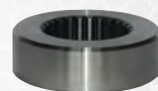

Reaction arm cranked with lock on function, made of drop-forged chrome-vanadium steel

Reaction arm made of light alloy, straight with adjustable locking knob with movable square-end and retaining ring.  
*More information on Page 52.*

Reaction ring for bespoke reaction arm design

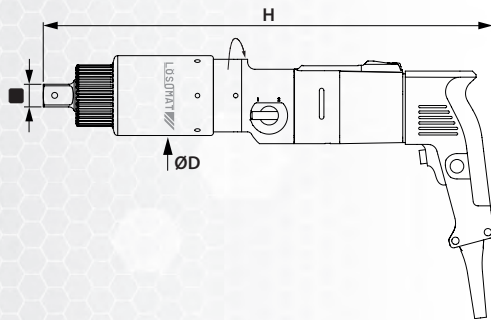
**Technical data**

LDE series - straight version

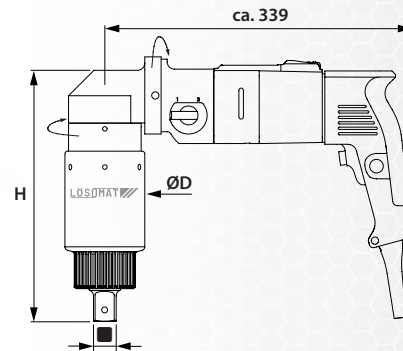

LEW series - angled version

**LDE series - straight version**

Type	N·m min <sup>*1</sup> /max <sup>*2</sup>	lbf·ft min <sup>*1</sup> /max <sup>*2</sup>	~ U/min	■	Ø D mm	H mm	kg <sup>*3</sup>
LDE - 05	90 - 500	70 - 370	44	3/4"	80	405	4.5
LDE - 075	100 - 750	80 - 550	22	3/4"	80	439	5.0
LDE - 15	250 - 1500	180 - 1110	20	1"	88	455	6.1
LDE - 28	500 - 2800	370 - 2050	6	1"	88	495	7.3
LDE - 40	750 - 4000	550 - 2950	5	1"	88	495	7.3
LDE - 60	700 - 6000	520 - 4400	3.5	1 1/2"	102	515	9.2
LDE - 70	900 - 7500	660 - 5500	3	1 1/2"	128	531	12.1
LDE - 90	1100 - 9000	810 - 6600	2.5	1 1/2"	142	542	14.0
LDE - 120	1800 - 13000	1330 - 9500	2	1 1/2"	174.5	560	20.0

\*1 Lowest torque in 2nd gear

\*2 Maximum torque in 1st gear

\*3 Without reaction arm

All rights reserved. Subject to modifications without prior notice.

**LEW series - angled version**

Type	N·m min <sup>*1</sup> /max <sup>*2</sup>	lbf·ft min <sup>*1</sup> /max <sup>*2</sup>	~ U/min	■	Ø D mm	H mm	kg <sup>*3</sup>
LEW - 05	90 - 500	70 - 370	44	3/4"	80	187	5.8
LEW - 075	100 - 750	80 - 550	22	3/4"	80	220	6.4
LEW - 15	250 - 1500	180 - 1110	20	1"	88	236	7.3
LEW - 28	500 - 2800	370 - 2050	6	1"	88	276	8.6
LEW - 40	750 - 4000	550 - 2950	5	1"	88	276	8.6
LEW - 60	700 - 6000	520 - 4400	3.5	1 1/2"	102	296	10.7
LEW - 70	900 - 7500	660 - 5500	3	1 1/2"	128	311	12.9
LEW - 95	1100 - 9500	810 - 7000	2.5	1 1/2"	142	323	14.6
LEW - 120	1800 - 13000	1330 - 9500	2	1 1/2"	174.5	340	20.6

\*1 Lowest torque in 2nd gear

\*2 Maximum torque in 1st gear

\*3 Without reaction arm

All rights reserved. Subject to modifications without prior notice.



## THE LÖSOMAT CRANE TORQUE WRENCH

There are applications where electric torque wrenches have to provide even more power.

This includes crane assembly at great heights.

The LEW-60L and LEW-95L devices are specially designed for the HV bolted connections on the tower sections of the Liebherr HC and EC models.

LÖSOMAT also offers the complete package here for the demanding user. Starting from the gear unit diameter precisely matched to the tower section and conical impact sockets right up to the appropriate reaction arm made of high-performance aluminium.



In addition, higher loosening torques for disassembly, as well as special equipment and torque settings for other crane manufactures are available.

## Accessories for Crane Torque Wrench



HC Design



EC Design



SL type impact socket

Reaction arms for other crane manufacturers on request.

## Technical data

Also available as a Heavy Duty version. LEW-60L with increased torque.

Type	N-m min <sup>*1</sup> /max <sup>*2</sup>	lbf-ft min <sup>*1</sup> /max <sup>*2</sup>	~ U/min	■	Ø D mm	H mm	kg <sup>*3</sup>
LEW - 60L	1200 - 6500	880 - 4800	3.5	1 1/2"	102	296	10.7
LEW - 95L	1100 - 9500	810 - 7000	2.2	1 1/2"	138	324	17.7

\*1 Lowest torque in 2nd gear

\*2 Maximum torque in 1st gear

\*3 Without reaction arm

All rights reserved. Subject to modifications without prior notice.

## The LÖSOMAT Steel Structure Torque Wrench

The steel structure torque wrench must be light but rugged in design for the assembly of bridges or steel construction projects.

LÖSOMAT has specialised in such situations. Decades of experience and development work, combined with the known high quality requirements, are clearly demonstrated by the torque wrenches in this range.

As with all series devices, you can rely on the acknowledged torque precision of these special versions.



### Technical data

Type	N·m min <sup>*1</sup> /max <sup>*2</sup>	lbf·ft min <sup>*1</sup> /max <sup>*2</sup>	~ U/min	■	Ø D mm	H mm	⚖ <sup>*3</sup> kg
LDE - 09ST	120 - 900	90 - 670	19.0	3/4"	80	439	5.2
LDE - 16ST	300 - 2200	220 - 1620	7.0	1"	88	472	6.6
LDE - 28ST	450 - 3200	330 - 2360	6.1	1"	88	495	7.3
LEW - 09ST	120 - 900	90 - 670	19.0	3/4"	80	220	6.5
LEW - 16ST	300 - 2200	220 - 1620	7.0	1"	88	253	7.9
LEW - 28ST	450 - 3200	330 - 2360	6.1	1"	88	276	8.6

\*1 Lowest torque in 2nd gear

\*2 Maximum torque in 1st gear

\*3 Without reaction arm

All rights reserved. Subject to modifications without prior notice.

## LÖSOMAT Steel Structure Torque Wrench

- » LDE-/LEW-09ST; Tightening of HV-connections from M12 to M24 (10.9)
- » LDE-/LEW-16ST; Tightening of HV-connections from M16 to M30 (10.9)
- » LDE-/LEW-28ST; Tightening of HV-connections from M20 to M36 (10.9)

